

Extrude Hone

AFM Abrasive Flow Machining

VECTOR™



Flexible Deburring and Polishing System

The Extrude Hone VECTOR™ Abrasive Flow Machining (AFM) system is an extremely flexible machine. It is capable of polishing large extrusion and forming dies, deburring and polishing precision parts in small batch quantities or medium to large volume production.

A wide selection of available media cylinder diameters offer a broad choice of pressure ranges to meet specific production requirements. The VECTOR features an ergonomic, user-friendly design that is easy to maintain. A broad work table accommodates large components and heavy tooling.

A standard feature on the VECTOR is a PLC – monitoring and saving all major processing data. An easy-to-use touch screen operator interface makes standard machine functions clear and simple and allows input of processing parameters.

System Features at a Glance

- ***Individually configurable AFM system***
Various options create a tailor-made system.
- ***Ergonomic and user-friendly***
Ease of use and reduced worker fatigue.
- ***Fast set-up and change of media***
Generously dimensioned machining area for large workpieces and rapid tool change.
- ***Controlled production***
State-of-the-art control system stores and monitors all major process data.
- ***All process data at a glance***

•
Defined interfaces are available.

Technical Data VECTOR™ Series

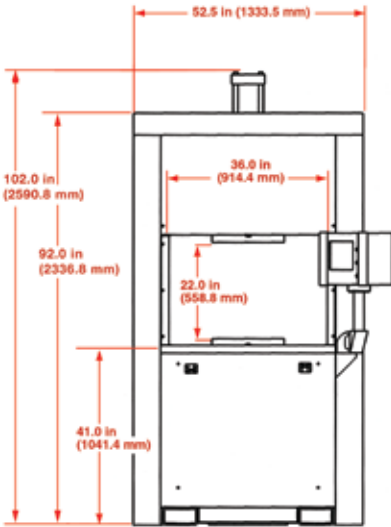
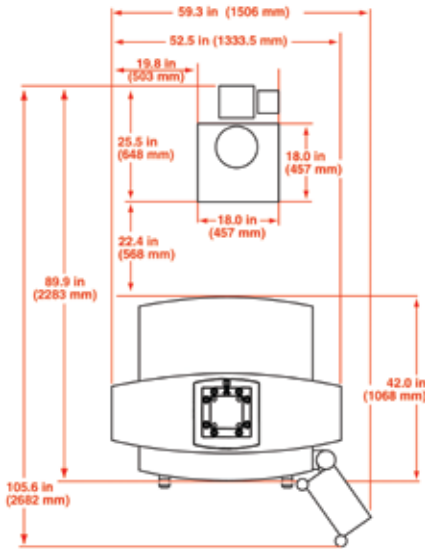

Machine Specifications

VECTOR series Abrasive Flow Machine consists of a machine base with covers, and a tabletop.

Height fully open	102 in (2590 mm)
Height closed	92 in (2335 mm)
Width	52.5 in (1335 mm)
Depth	42 in (1070 mm)
Tabletop height	41 in (1040 mm)

Working distance between clamp columns	36 in (915 mm)
Estimated weight	4,300 lbs (1955 kg)

Media Delivery

Media delivery is reciprocating between the top and bottom Assemblies. Both assemblies consist of media cylinders, pistons, seals and caps.

Hydraulic Specifications

Main components of the hydraulic system are a hydraulic power unit, two media hydraulic cylinders, and two clamp cylinders with an air/oil pump assist.

Standard Power Unit

Reservoir	20 gallon (75.7 L)
Pump capacity @ 1,750 rpm	5 GPM (18.9 L/m)
Pressure	350-1500 psi (23.8 - 102 bar)

Clamp Cylinders

(Clamping is powered hydraulically)

Bore diameter	5 in (127 mm)
Stroke	20 in (508 mm)
Maximum opening	22 in (558.8 mm)
Minimum opening	2 in (50.8 mm)

Electrical Specifications

The machine is controlled by a PLC. The operator interface terminal is a touch screen. Standard functions include remote media pressure adjustment, automatic and manual mode, displacement counter, cycle counter, and cycle timer. The machine process parameters are preset via the operator interface terminal and can also be monitored on the terminal once the automatic cycle has been initiated.

Electrical

Voltage	3 phase 230/460 volts 60 Hz
Motor	5 horsepower
Peak amperage	15/7.5 amps

Controls

Standard controller Micro Logic 1200*

* other controls available as option

Fluid Connection Specifications

Hydraulic

Ports	NPT
Hose/Tube	37° JIC

Water

Ports	NPT
Hose/Tube	NPT and/or Push Lok

Pneumatic

Ports	NPT
Hose/Tube	Push Lock

Accessories / Options

- Sliding table
- Fixture cart
- Media heater and cooler
- Separate media delivery
- Blow-off station
- Advanced Autoflow™ Controls
- Real time display of media piston position

System Configurations

	VECTOR Series							VECTOR High-Pressure			
	Media Cylinder Diameter	Hydraulic Cylinder Diameter	Media Stroke Length	Media Capacity	Hydraulic Flow Rate	Media Flow Rate	Standard Power Unit	Media Pressure min/max	Expansion Diameter max*	Media Pressure min/max	Expansion Diameter max*
Vector 100	4 in (100 mm)	6 in (150 mm)	12.5 in. (320 mm)	157 cu.in. (2.6 L)	5 gpm (18.9 L/m)	2.2 gpm (8.3 L/m)	5 hp (3.73 kw)	775/3000 psi (53/204 bar)	5 in. (127 mm)	N/A	N/A
Vector 150	6 in (150 mm)	6 in (150 mm)	12.5 in. (320 mm)	353 cu. in. (5.8 L)	5 gpm (18.9 L/m)	5 gpm (19 L/m)	5 hp (3.73 kw)	350/1500 psi (24/102 bar)	7.4 in. (188 mm)	350/2400 psi (24/163 bar)	6.5 in. (165 mm)
Vector 200	8 in (200 mm)	6 in (150 mm)	12.5 in. (320 mm)	628 cu. in. (10.3 L)	5 gpm (18.9 L/m)	8.8 gpm (33.3 L/m)	5 hp (3.73 kw)	200/900 psi (13.6/61 bar)	9.9 in. (252 mm)	200/1440 psi (13.6/98 bar)	8.7 in. (221 mm)
Vector 250	10 in (255 mm)	6 in (150 mm)	12.5 in. (320 mm)	981 cu.in. (16.1 L)	5 gpm (18.9 L/m)	14 gpm (53 L/m)	5 hp (3.73 kw)	125/600 psi (8.5/41 bar)	12.3 in. (312 mm)	125/960 psi (8.5/65 bar)	10.9 in. (277 mm)
Vector 300	12 in (305 mm)	8 in (200 mm)	12.5 in. (320 mm)	1413 cu. in. (23.2 L)	5 gpm (18.9 L/m)	20 gpm (76 L/m)	5 hp (3.73 kw)	90/375 psi (6/25.5 bar)	14.8 in. (376 mm)	90/600 psi (6/41 bar)	13 in. (333 mm)

*Maximum expansion diameter at maximum media pressure

More information about finishing equipment...

Kennametal Extrude Hone

1 Industry Boulevard
Irwin, PA 15642 USA
Tel.: 724-863-5900
Fax: 724-863-8759
www.extrudehone.com

